

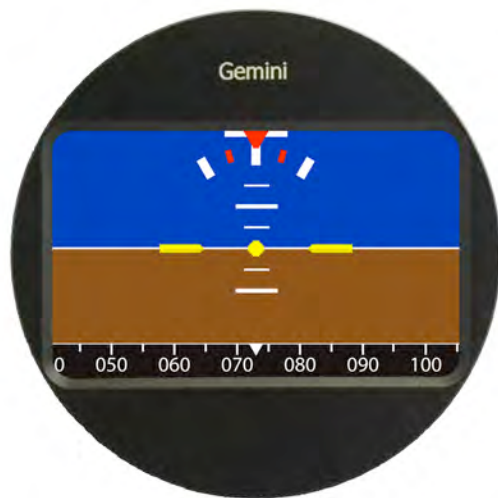

**Gemini Series ADI**  
**Installation/User Manual**  
**8300-082**

Rev B





## Table of Contents

|   |           |
|---|-----------|
| <b>Document Revision Level &amp; Notes .....</b>        | <b>4</b>  |
| <b>Instrument Installation .....</b>                    | <b>6</b>  |
| <b>Mounting Considerations.....</b>                     | <b>6</b>  |
| <b>Wiring Considerations .....</b>                      | <b>6</b>  |
| <b>Pitot and Static Connections .....</b>               | <b>6</b>  |
| <b>RFI/EMI Considerations .....</b>                     | <b>7</b>  |
| <b>Gemini Series ADI Operation .....</b>                | <b>8</b>  |
| <b>GPS Signal Acquisition .....</b>                     | <b>8</b>  |
| <b>Using the Touch Screen .....</b>                     | <b>9</b>  |
| <b>Slip Indicator Centering .....</b>                   | <b>10</b> |
| <b>Low Airspeed Warning Setting.....</b>                | <b>11</b> |
| <b>Info Page Display .....</b>                          | <b>12</b> |
| <b>Slewing DG When GPS Signal Is Lost .....</b>         | <b>13</b> |
| <b>Electrical Pin-out .....</b>                         | <b>14</b> |
| <b>Gemini ADI Wiring Diagram .....</b>                  | <b>15</b> |
| <b>Warranty On TruTrak Flight Systems Products.....</b> | <b>16</b> |
| <b>Return Merchandise Policy And Procedure .....</b>    | <b>18</b> |

**Document Revision Level & Notes**

| <b>Revision</b> | <b>Date</b> | <b>Description</b>   | <b>Page #</b> |
|-----------------|-------------|----------------------|---------------|
| A               | 1/2012      | Initial Release      |               |
| B               | 2/14/12     | Minor clarifications | 6, 9, 14      |
|                 |             |                      |               |
|                 |             |                      |               |
|                 |             |                      |               |
|                 |             |                      |               |
|                 |             |                      |               |

This page intentionally blank

## **Instrument Installation**

### **Mounting Considerations**

The Gemini ADI unit is designed to mount in the aircraft instrument panel. Maximum recommended viewing angle should be no more than 20 deg. The maximum mounting angle the instrument can accommodate is 10 degrees longitudinal axis and 0 degrees lateral axis. The primary unit location should minimize pilot head movement when transitioning between looking outside of the cockpit and viewing/operating the instrument. The location should be such that the instrument is not blocked by the glare shield on top, or by the throttles, control yoke, etc. on the bottom. Use aircraft installation standards for mounting and support of the instrument.

### **Wiring Considerations**

Use AWG #24 or larger wire for all connections unless otherwise specified. The standard solder pin contacts supplied in the connector kit are compatible with up to AWG #18 wire. In cases where some installations have more than one component sharing a common circuit breaker, sizing and wire gauge is based on length of wiring and current draw on units. In these cases, a larger

gauge wire such as AWG #20 may be needed for power connections. Do not attach any wires to the outside of the instrument or route high current wires within six (6) inches of the programmer. Ensure that routing of the wiring is not exposed to sources of heat, RF or EM interference. Check that there is ample space for the cabling and mating connectors. Avoid sharp bends in cabling and routing near aircraft control cables. Do not route the COM antenna coax near any instrument components. The Gemini should be connected to the avionics master bus, not the battery master bus. This way the instrument is in a powered down state during engine starting.

### **Pitot and Static Connections**

The preferred method of connecting the static line is a tee fitting near the aircraft's altimeter. The static line requires due care in its installation as excessive lag or insufficient static orifices can cause discrepancies in instrument information. The importance of a good static port and line cannot be overstated. In some cases problems can be caused by having a large number of devices connected to a single, insufficient, static port. In other cases, the static line itself is adequate but there are one or more devices connected to the

same line, one of which has a large static reservoir. A simple remedy for this problem if it occurs is a tee-fitting near the static port, and a dedicated line to the instrument. Obviously, an insufficiently-large orifice coupled with large static reservoirs can aggravate the problems associated with lag.

### **RFI/EMI Considerations**

The instrument is shielded and does not generate any appreciable level of electromagnetic interference. It has a low-current draw and cannot contribute to RF interference. The solid-state gyros used in the instrument are susceptible to outside stray RFI. Be sure all COM antennas are properly installed, tuned, and grounded as stray RFI can cause unreliable attitude information.

## Gemini Series ADI Operation

### GPS Signal Acquisition

The Gemini Series ADI has minimal required setup before the first flight. Ensure that the instrument is powered down until after the engine is running. Once the engine is running and with the aircraft still stationary, apply power to the Gemini. The DG pointer has different colors to show GPS signal status:

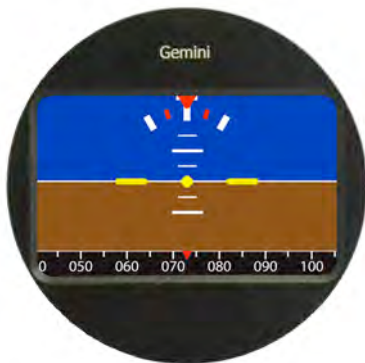

**Red**=No GPS signal detected

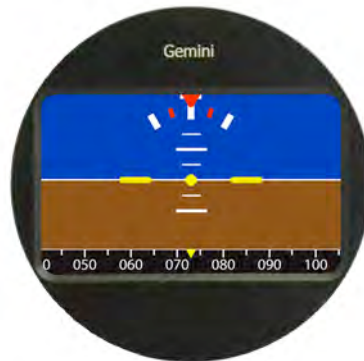

**Yellow**=GPS signal detected, but no GPS fix

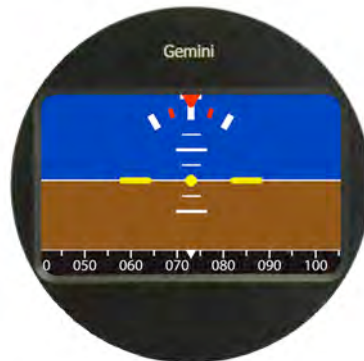

**White**=GPS signal detected and good GPS fix

## Using the Touch Screen

The Gemini ADI has a touch screen interface. It is a capacitive touch display and therefore does not require very much pressure on the display to operate. There are several functions of the touch screen with the Gemini ADI; centering the slip indicator, the Low Airspeed warning, displaying the Info page, and slewing the DG when GPS signal is lost.

The upper left corner of the display will act as a 'control key' for these functions. **\*The 'bulls-eye' indicates the location to touch, but does not actually appear on the screen.**

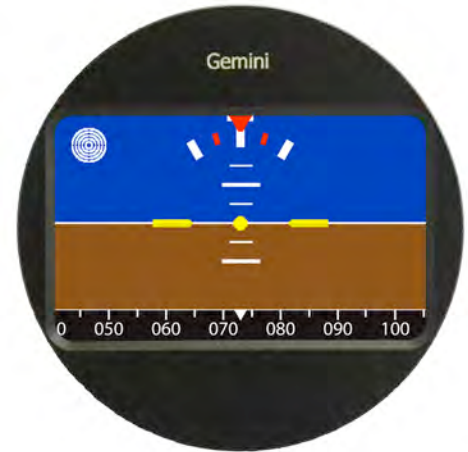

## Slip Indicator Centering

It is best to center the slip indicator while the aircraft is on the ground and stationary. To center:

- 1-Touch and hold 'control key' in upper left corner of display.
- 2-While holding 'control key', touch just to the right of the slip pointer.

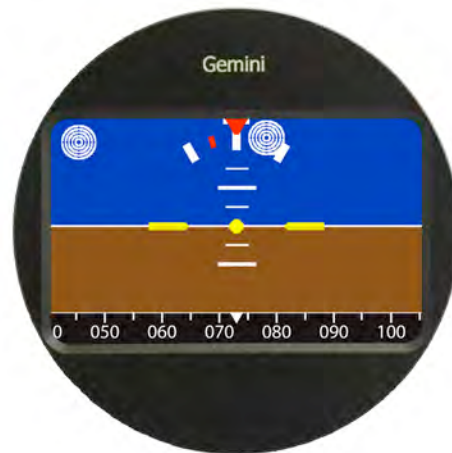

## Low Airspeed Warning Setting

This operation must be performed in flight. The pitot line must be connected to the instrument. To set LAS warning:

- 1-Fly at the desired indicated airspeed for the low airspeed warning setting.
- 2-Touch and hold 'control key' in upper left corner of display.
- 3-While holding 'control key', touch the upper right corner of the display.
- 4-The center dot of the reference airplane will flash confirming that the LAS warning has been set.

Once a value has been set for the LAS warning the dot of the reference airplane will be solid red when IAS is  $\frac{1}{2}$  of the set value. It will flash when  $\frac{1}{2}$  of the value is reached and will continue flashing until the IAS is above the LAS warning setting. At that point it will turn back to yellow.

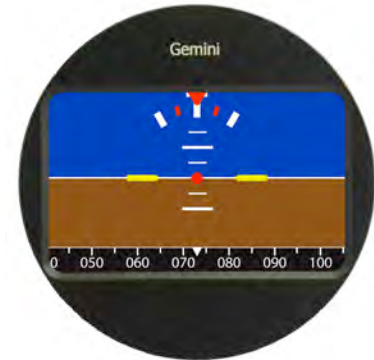
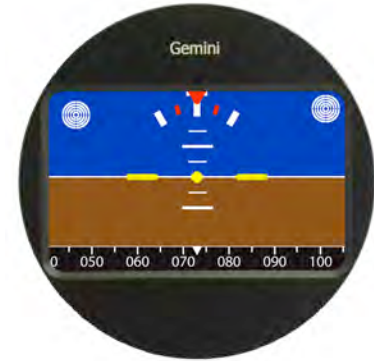

Red dot showing IAS is less than  $\frac{1}{2}$  of set IAS value

## Info Page Display

The unit serial number and software revision level can be displayed by touching the right-center area of the display, shown below.

**1**-Touch and hold the right-center area to display the info page. The instrument will return to normal flight screen when the screen is released.

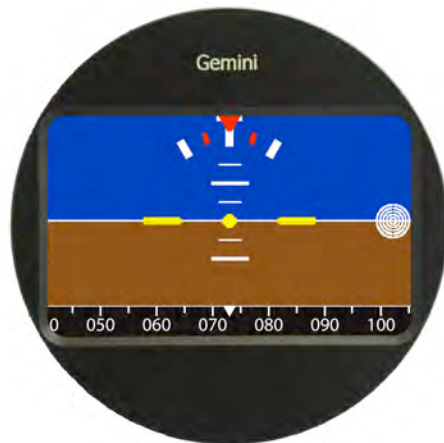

## Slewing DG When GPS Signal Is Lost

When the GPS signal is lost the DG will enter the free gyro mode. This mode has no track or heading reference so the DG must be set against a compass heading or other directional reference. There are several options for changing the DG direction.

**1-**To slew the DG to the right, touch and hold the 'control key'. While holding the 'control key' touch and hold the lower right corner of the display. The longer both keys are held, the faster the DG will slew.

**2-**If the 'control key' is released first the DG will continue to slew in that direction at the same rate. To stop the DG movement, tap the 'control key'.

**3-**To slew the DG to the left, follow the same procedure except touch the 'control key' and the bottom left corner of the display.

Small adjustments can be made to the DG to help with a small offset.

**1-**Touch and hold the lower corner corresponding to the direction of desired DG movement; i.e. lower left corner for left movement, lower right corner for right movement. Then tap the 'control key'. Each tap will step the DG in the desired direction by small increments.

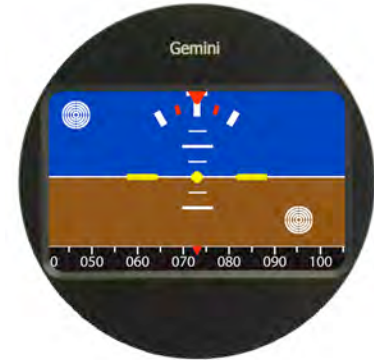

Slewing the DG to the right

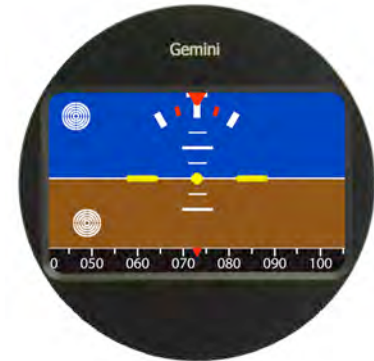

Slewing the DG to the left

## Electrical Pin-out

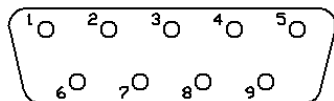

View from back of unit or  
wire side of connector

Rear 9-Pin Connector P101  
viewed from rear of unit

| P101 Pin | Function  | Notes  |
|----------|---|--|
| 1        | <b>Aircraft Power</b> (8-30 VDC)  | 0.2 mA @ 12 V, 0.11 mA @ 24 V  |
| 2        | <b>Dimmer Control</b>   | Variable voltage input, 0-12 Volts   |
| 3        | <b>RS-232 Output</b>  | Internally connected to pin 6  |
| 4        | <b>TCB-B<sub>1</sub></b>  | Must be an unshielded, twisted pair. Only used for interface to other TTFS products. |
| 5        | <b>TCB-A<sub>1</sub></b>  |  |
| 6        | <b>RS-232 Input from GPS</b> (NMEA 0183 or Aviation format is accepted at baud rates of 4800 or 9600) |  |
| 7        | <b>TCB-B<sub>2</sub></b>  | Must be an unshielded, twisted pair. Only used for interface to other TTFS products. |
| 8        | <b>TCB-A<sub>2</sub></b>  |  |
| 9        | <b>Ground Connection</b>  |  |

# Gemini ADI Wiring Diagram

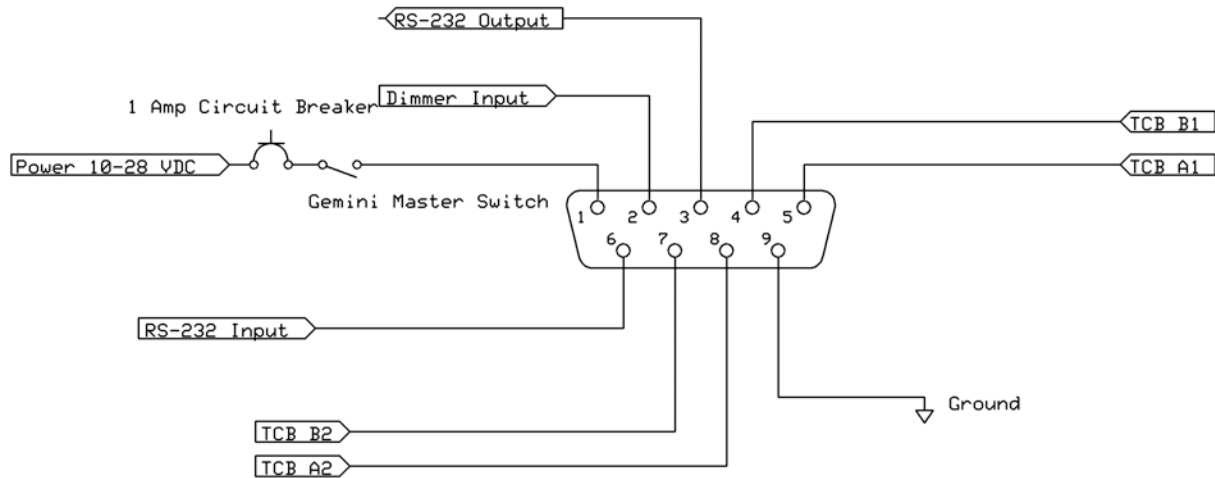

## **Warranty On TruTrak Flight Systems Products**

We at TruTrak Flight Systems know how important it is to feel as though the customer is purchasing a product that the manufacturer is going to stand behind. For this reason we want offer more than the basic one-year warranty that is standard to this industry. The warranty on all TruTrak products will be three years from the date of purchase. Abuse and misuse of a product are not covered under this warranty. Modification to a product may void the warranty, as well as carry a penalty when upgrading to another product. This three-year warranty will be for all products except the Pictorial Turn & Bank, which will continue to have a warranty of one year from the date of purchase.

This page intentionally blank

## **Return Merchandise Policy And Procedure**

Under no circumstances should products be returned to TruTrak without first obtaining a Return of Merchandise Authorization number (RMA #) from TruTrak. An RMA# may be obtained by contacting us at 866-878-8725.

Products that do not have an RMA # will not be processed.

Please include documentation stating the reason for the return and describing any symptoms, failure modes, suspected causes of damage, diagnostics performed, data collected, etc.

Product(s) should be packaged in their original shipping containers. In lieu of this, they should be very carefully packaged in containers suitable to protect them during transit. For your protection, items should be insured for the full value. Note that damage caused during shipping will not be repaired under warranty.

The outside of the box must be clearly marked with the RMA # issued by TruTrak and the RMA # must also be noted on the return documents.

Products will be returned to the customer at no charge via FedEx Ground or UPS Ground. If customer requests expedited shipping (2<sup>nd</sup> Day or Overnight) they will be charged the shipping cost and must supply a credit card number.

### **INTERNATIONAL SHIPMENTS:**

TruTrak sends all International shipments with an insurance value on all products. The customer is responsible for any and all fees, including the cost of shipment, duties, and taxes associated with the shipment.

When sending products to TruTrak for repair or otherwise please be advised that the customer is responsible for all charges and fees associated with shipment. For your protection, items should be insured for the full value.

TruTrak states on all product returns “WARRANTY REPAIR AT NO CHARGE TO CUSTOMER. A COMMERCIAL INVOICE VALUE OF \$\_\_ GIVEN FOR INSURANCE PURPOSES ONLY”

Please keep in mind that your government or another entity in your country may impose a charge for custom and/or brokerage fees, duties and taxes on items received from the US. These charges do not originate from our company nor do we benefit from them in any way. You are responsible for payment of all custom and brokerage fees, duties and taxes that may be imposed when these goods are imported into your country.

Send UPS/FedEx/DHL return shipments to:

TruTrak Flight Systems, Inc., 1500 South Old Missouri Road, Springdale, AR 72764  
USA  
Attention: Returns Dept.      RMA# \_\_\_\_\_

TRUTRAK FLIGHT SYSTEMS

**1500 S. Old Missouri Road  
Springdale, AR 72764**

POSTAL SERVICE ADDRESS

P.O. Box 189  
Springdale, AR 72765-0189

**Ph: 479-751-0250 Fax: 479-751-3397**

**Toll free: 866-TRUTRAK**

**866-(878-8725)**

[www.trutrakap.com](http://www.trutrakap.com)